

INSTALLATION AND OPERATION INSTRUCTIONS BEER PUMP PANELS

MODEL NO.

- 63134-1
- 63134-2
- 63134-3
- 63134-4

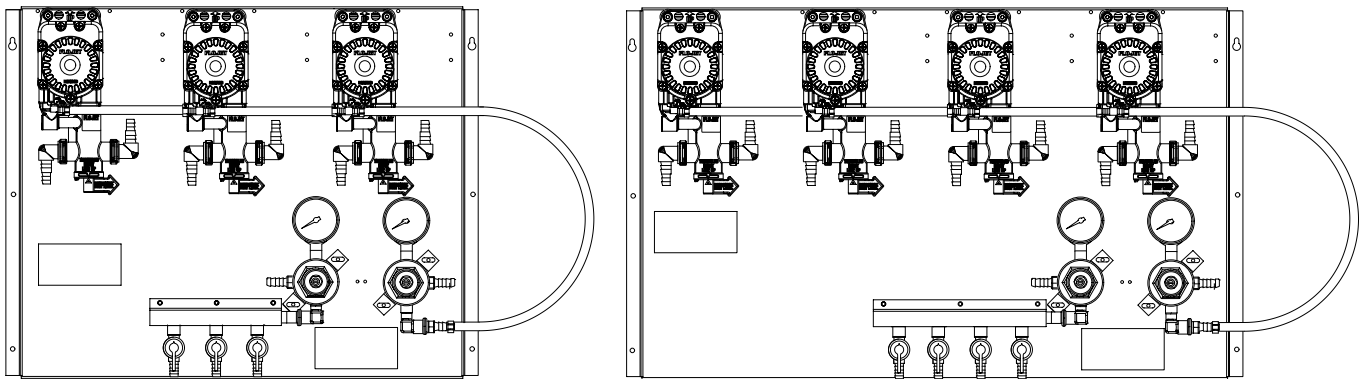
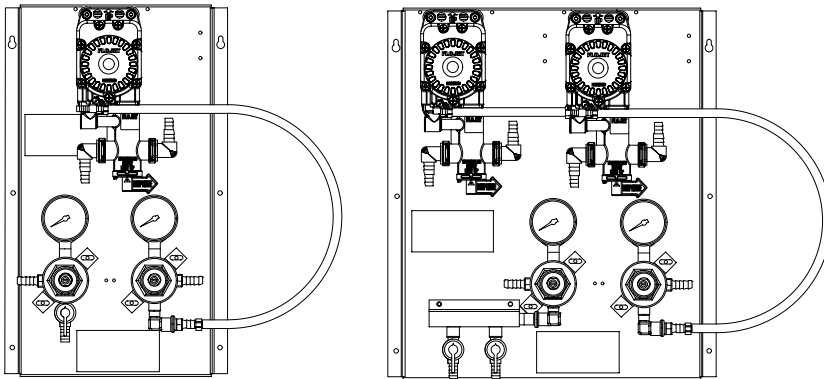

IMPORTANT INFORMATION

This manual has been prepared to assist you in the operation of Perlick Beer Pump Panel System.

We dedicate considerable time to ensure that our products provide the highest level of customer satisfaction. If service is required, your dealer can provide you with a list of qualified service agents. For your own protection, never return merchandise for credit without our approval.

We thank you for selecting a Perlick product and assure you of our continuing interest in your satisfaction.

Table of Contents

Installing the Panel	2
Panel Diagram	3
How to Operate the Beer Panel.....	4
Beer Pump Diagram	5
Cleaning Diagram	6
Cleaning Instructions	7
Winterizing a System with Beer Pumps.....	7
Replacement Parts	7



Installation – Beer Pump Panels

- Use panel as a template to mark where holes should be drilled on cooler wall. (Note: Make sure panel is level and pumps are in the vertical position).
- Drill $\frac{9}{64}$ " pilot holes in cooler wall. Use fasteners provided in installation kit to mount the beer pump panel to the cooler wall.
- Push CO₂ supply line over **Keg Pressure Supply** barbed inlet. (See diagram on page 3). Position clamp over joint and tighten. (Note: A safety Relief Valve should be installed between supply tank and shut-off point on carbon dioxide supply line. Relief setting depends on maximum system pressures).
- Push air or CO₂ supply line over **Beer Pump Pressure** barbed inlet. (See diagram on page 3). Position clamp over joint and tighten. If using compressed air, make sure air supply is clean and dry. Air must have a pressure dew point of 30°F. or lower to ensure pumps operate properly.
- Push beer line (from trunk housing) over barbed **Liquid outlet** on flow reversal valve. (see diagram on page 3). Position clamp over joint and tighten.
- Push connector hose over **Liquid inlet** on beer pump inlet fitting. (See diagram on page 3). Position clamp over joint and tighten. (Note: Connector hose should not exceed 10 feet in length).
- Install washer into hex nut on opposite end of connector hose. Connect to top threaded fitting of Perlick Smart Coupler.
- Cut a piece of CO₂ tubing and push one end onto barbed CO₂ outlet. (See diagram on page 3). Position clamp over joint and tighten. Push the other end over the barbed gas inlet on the Perlick Smart Coupler. Position clamp over joint and tighten.

CAUTION: IF USING CO₂ AS A PRESSURE SUPPLY FOR PUMPS, PUMP EXHAUST MUST BE VENTED TO A WELL VENTILATED AREA TO AVOID POSSIBLE ASPHYXIATION.

Diagram – Beer Pump Panel Diagram

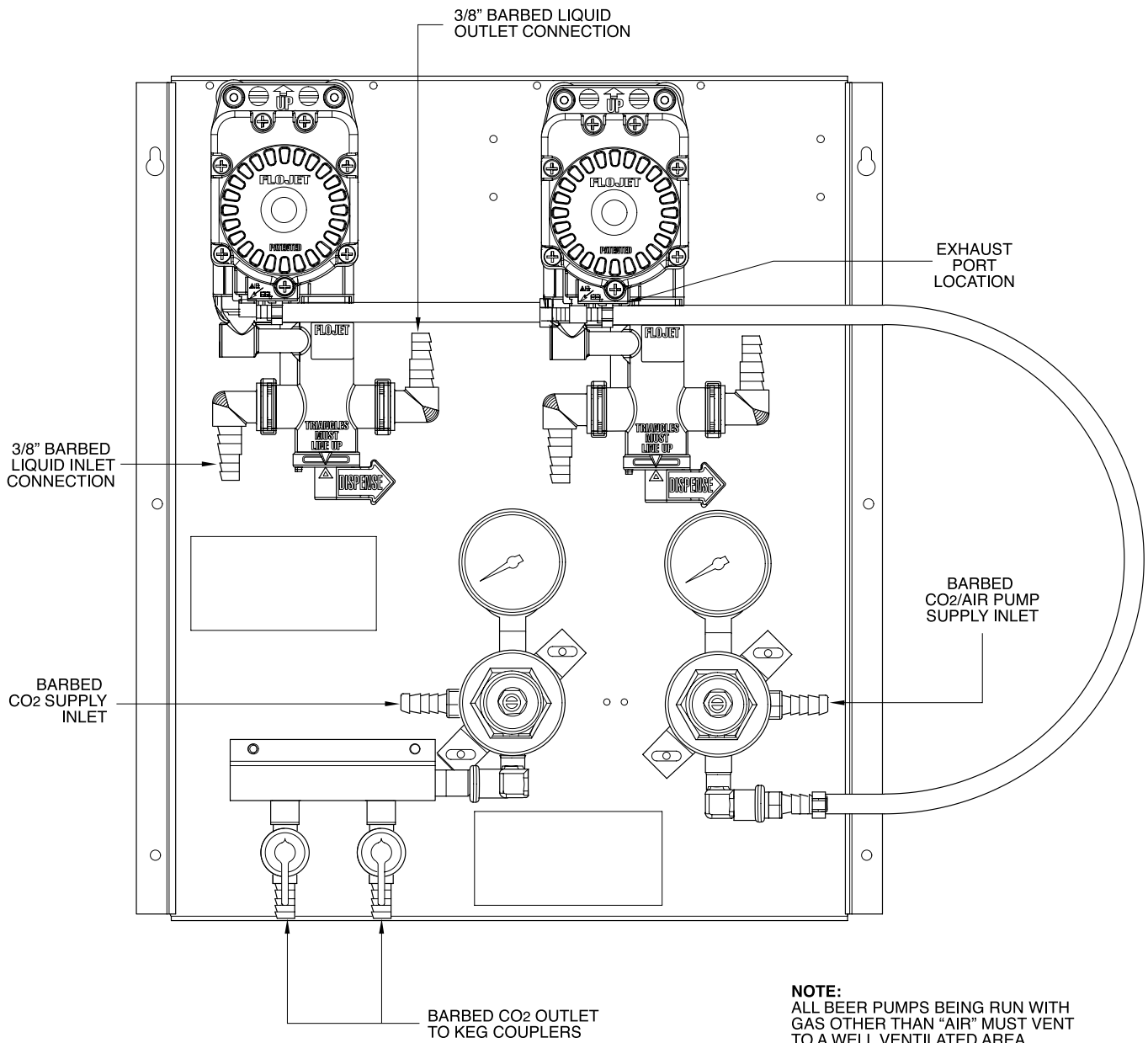

How to Operate – Beer Pump Panels

- **Adjust primary CO₂ regulator** by turning adjusting screw counterclockwise until it turns freely, then turn hand valve counterclockwise on CO₂ cylinder to the fully open position. Next, turn regulator adjusting screw clockwise until desired pressure is reached.

Note: If CO₂ is only being used for keg-applied pressure, adjust to approximately 40 psig. If CO₂ is being used to supply beer pumps, adjust to the required system pressure plus an additional 15 psig.

- **Adjust the air compressor output regulator** pressure to a minimum of 15 psig. greater than the maximum required system pressure required to operate the beer pumps. Maximum setting 100 psig.
- **Adjust secondary CO₂ regulator** which supplies the keg pressure located on the beer pump panel to the proper pressure setting. Setting depends on beer brand and temperature. Desired goal is to maintain the natural carbonation in the beer. Open the shut-off valves.
- Ensure the Probe Valve on the Perlick Smart Coupler is in closed position. *See figure 1.* Ensure the Beer Pump Flow Reversal/Dispense handle is in the dispense position. Adjust the **Secondary Air/ CO₂ regulator** located on the beer pump panel to a minimum operating pressure of 10 psig.

- Connect the coupler to a regulated water supply with pressure less than 30 psig. **Note: Pump damage may occur with pressure higher than 30 psig.**
- Open the water supply. Then open probe valve on Perlick Smart coupler to the 45° position. *See figure 2.* The beer pump will slowly pump up the beer line in the trunk housing to set psig. Note: If pump continues to run for longer than expected, check lines for possible leaks at one or more of the connections.
- Gradually increase secondary regulator pressure to the designed system pressure to achieve a flow rate of one gallon per minute from the dispensing head. **Note: Maximum beer pump operating pressure is 90 psig.**
- Open dispensing head faucet to purge air trapped within the tubing.
- Check all gas and liquid line fittings and connections for leaks.
- Close probe valve on Perlick Smart Coupler. (*See figure 1*) and disconnect coupler from regulated water source.
- Clean beer system. After cleaning and rinsing the system, make sure the beer line is full of cold water (beer dispensing from warm beer lines will be poor quality).
- Tap fresh keg with Perlick Smart Coupler. Open dispensing head faucet until clear beer flows.

Smart Coupler Probe Valve Lever Positions

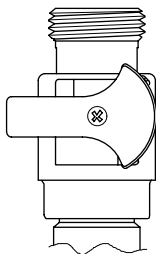

Figure 1
Closed Position

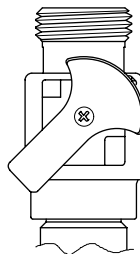

Figure 2
45° or Cleaning Position

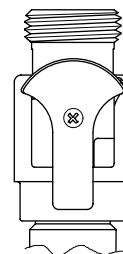

Figure 3
Open Position

Diagram #2 – Beer Pump

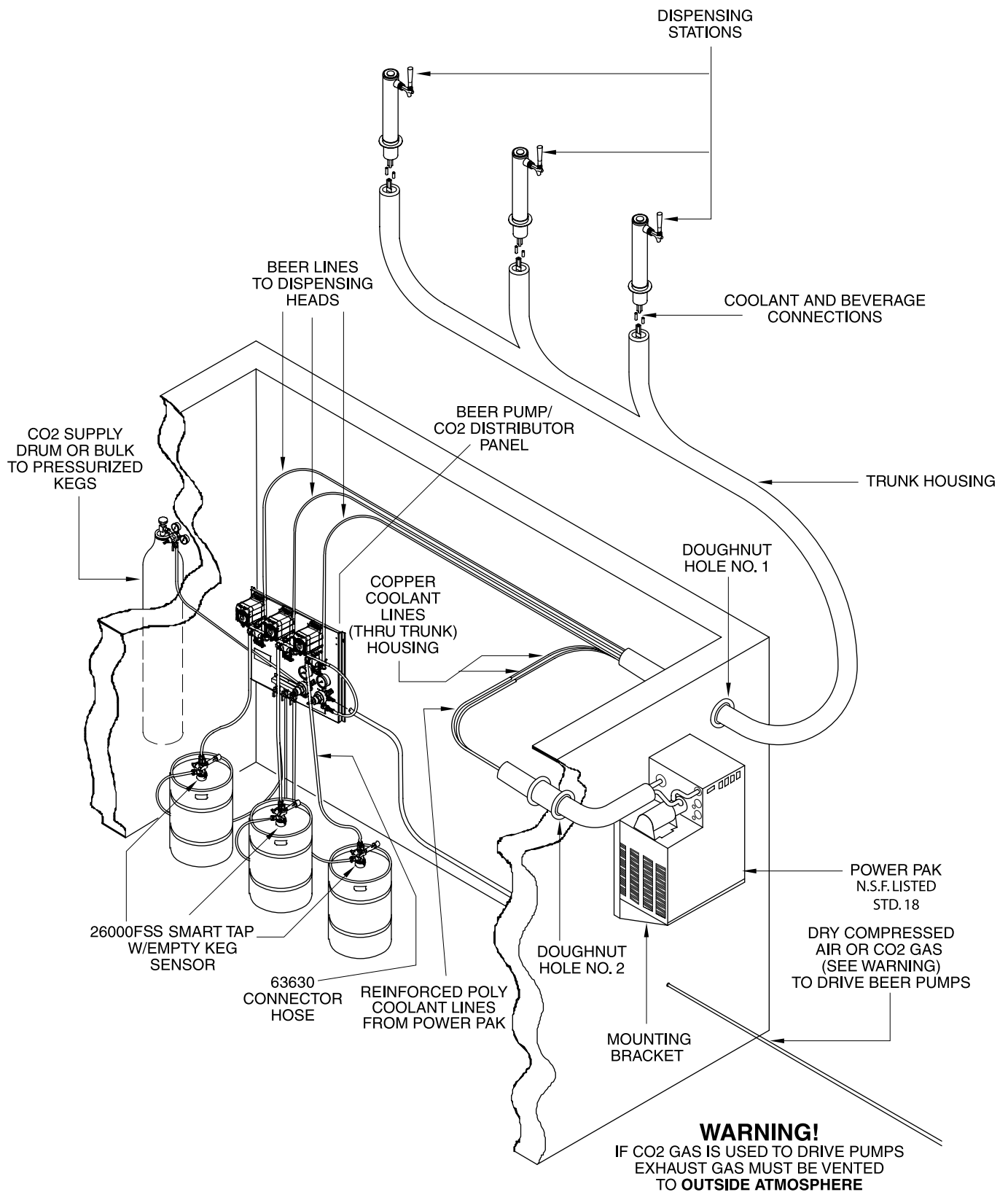
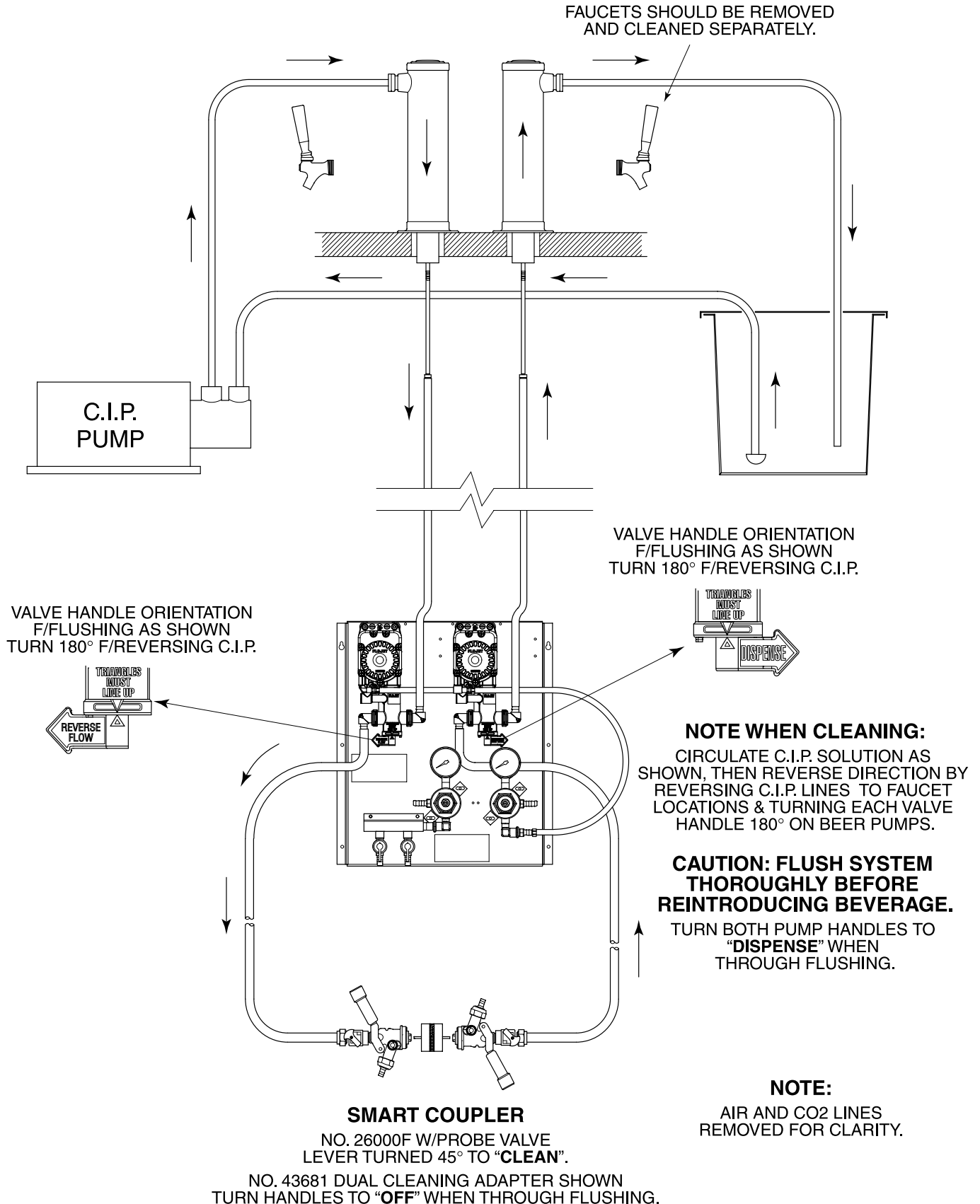

Diagram #3 – Cleaning Diagram



Cleaning Instructions

General Information

- The cleaning of beer lines with the new integral flow reversal feature incorporated into the Perlick Beer Pump gives the line cleaner numerous configurations for line cleaning. Although the Perlick Beer Pump can be used as an in-line pump for moving the solution from the coupler to the faucet due to its capability of working with negative lift, the following is the recommended method for cleaning beer lines with the Perlick Beer Pump with integral flow reversal installed.

Cleaning from the Tap/Faucet End

- Disconnect Perlick Smart Couplers from the kegs following Smart Coupler instructions.
- Couple the two Smart Couplers together using Dual Cleaning Adapters (43681) which have a pin of sufficient length to lift the internal slide within the Smart Coupler to allow proper flow.
- Determine which sets of lines will be cleaned together and rotate the Dispense/Reverse Flow handle to the Reverse Flow position on the line which fluid will be pushed back from the Tap/Faucet.
- Rotate the Smart Coupler Valve Handle to the Clean position on both couplers (See Smart Coupler Instructions).
- Relieve the line pressure by opening the faucets.
- Remove the faucet from the line, which will have the Beer Line Cleaner pump connected to it.
- Connect Beer Line Cleaner pump to the shank.
- Follow standard line cleaning procedures. Perlick recommends that the lines first be flushed with clean warm water (Water temperature not to exceed 100°F). Mix line-cleaning solution per the manufacturer's directions. Circulate the solution thoroughly (Time for circulation dependent on the length of the system and pump capabilities). Rinse the lines using clean cold water (Ensure all line cleaning solution has been removed from the lines to prevent hazardous results).

- Disconnect line-cleaning pump.
- Remove and clean taps and couplers.
- Reconnect taps and couplers and return Beer Pump Dispense/Reverse Flow valve to the Dispense position.
- Reconnect couplers to keg and open dispensing head faucets until clear beer flows.

Winterizing Systems with Beer Pumps

- When a beer system with beer pumps will be shut down for an extended period, clean the system thoroughly. After completing the rinsing step, prepare a mixture of 50% food grade Glycerine and 50% water. Load the lines with this mixture and make sure both ends of the system are closed. Glycerine/water mixture should remain in the lines for the duration of the shutdown period.

Replacement Parts

44	Air valve
40115	Regulator body
40129	Regulator body
43553A	Regulator repair kit
63705	Beer pump, Flo-Jet, w/CO2 elbow
63706	Flow reversal valve
63707	Elbow, flow reversal, 2/bag
63708	Fitting, tee, gas, barbed 1/4" with check valve
63709	Fitting, elbow, gas, barbed 1/4" with check valve
63710	Beer pump, Flo-Jet, w/CO2 tee



8300 West Good Hope Road • Milwaukee, WI 53223 • Phone 414-353-7060 • Fax 414-353-7069
Toll Free 800-558-5592 • E-Mail: Perlick@Perlick.com • www.Perlick.com

Perlick is committed to continuous improvement. Therefore, we reserve the right to change specifications without prior notice. Form No. Z2149A
Rev. 08.24.04